

METAL BAR GRATING
ENGINEERING
DESIGN
MANUAL

MBG Metal Bar Grating

A Division of

NATIONAL ASSOCIATION OF
ARCHITECTURAL METAL MANUFACTURERS

This manual was developed by representative members of the Metal Bar Grating Division (MBG) of the National Association of Architectural Metal Manufacturers (NAAMM) to provide their opinion and guidance on the procedures used in design calculations for metal bar grating. This manual contains advisory information only and is published as a public service by NAAMM. NAAMM disclaims all liability of any kind for the use, application or adaptation of material published in this manual.

Copyright © 2014
National Association of Architectural Metal Manufacturers
All Rights Reserved

METAL BAR GRATING ENGINEERING DESIGN MANUAL

Published and distributed by the

NATIONAL ASSOCIATION OF ARCHITECTURAL METAL MANUFACTURERS

800 ROOSEVELT ROAD, BLDG. C-312.....GLEN ELLYN, IL

60137

Phone (630)942-6591

Fax (630)790-3095

website: www.naamm.org

METAL BAR GRATING

This manual sets forth procedures used in design calculations for metal bar grating. The load bearing capabilities and deflections of grating are based on the structural properties of the bearing bars and the number of bearing bars supporting the load. Grating is designed so that the allowable stresses of the metals used are not exceeded when the design loads are applied or, if deflection governs, the specified allowances for deflection are not exceeded. Metric properties, with sample calculations, are included for metric conversions. All calculations are based on the *AISC Manual of Steel construction*, 9th edition. All spans are designed as simple spans.

The concentrated, uniform and partially distributed uniform loads used in the calculations are modeled as static loads. Static loads are typically used to evaluate the functionality for live loading pedestrian load applications. Examples 1 – 5 on the following pages present the formulas used for calculating the load and deflection values of static loads.

Heavy rolling loads are defined as Vehicular Loads. Examples 6 – 7 present the formulas used to calculate the values for welded and pressure locked gratings when subjected to vehicular loads. Example 8 presents the formulas used to calculate the values for riveted gratings subjected to vehicular loads.

The Load Criteria presented for Vehicular Loads on page 12 is intended to serve as a guide for common vehicular applications. This criteria is not intended to be all-inclusive and if your application is not clearly represented by one of these options, contact NAAMM or your nearest NAAMM MBG member company for assistance in evaluating your specific application.

NOMENCLATURE

a = length of partially distributed uniform load or vehicular load, parallel with bearing bars, in.

b = thickness of rectangular bearing bar, in.

c = width of partially distributed uniform load or vehicular load, perpendicular to bearing bars, in.

d = depth of rectangular bearing bar, in.

A_c = distance center to center of main bars, riveted grating, in.

A_r = face to face distance between bearing bars in riveted grating, in.

A_w = center to center distance between bearing bars in welded and pressure locked gratings, in.

C = concentrated load at midspan, pfw

D_c = deflection under concentrated load, in.

D_u = deflection under uniform load, in.

E = modulus of elasticity, psi

F = allowable stress, psi

I = moment of inertia, in⁴

I_{H20} = moment of inertia of grating under H20 loading, in⁴

I_b = I of bearing bar, in⁴

I_g = I of grating per foot of width, in⁴

I_n = moment of inertia of nosing, in⁴

K = number of bars per foot of grating width, $12"/A_w$

L = clear span of grating, in. (simply supported)

M = bending moment, lb-in
 M_b = maximum M of bearing bar, lb-in
 M_g = maximum M of grating per foot of width, lb-in
 N = number of bearing bars in grating assumed to carry load
 N_{bH20} = number of main bearing bars under load H20
 N_{cH20} = number of connecting bearing bars under load H20
 P_b = load per bar, lb
 P_u = total partially distributed uniform load, lb
 P_{uH20} = wheel load, H20, lb
 P_w = wheel load, lb
 S = section modulus, in³
 S_b = S of bearing bar, in³
 S_g = S of grating per foot of width, in³
 S_{H20b} = section modulus at bottom of grating under H20 loading, in³
 S_n = section modulus of nosing, in³
 U = uniform load, psf

ABBREVIATIONS

in. = inch
ft = foot
lb = pounds
lb-in = pound-inches
pftw = pounds per foot of grating width
psf = pounds per square foot
psi = pounds per square inch

METAL PROPERTIES

<u>Material</u>	Allowable Design Stress F psi	Yield Strength F _y psi	Tensile Strength F _u psi	Modulus of Elasticity E psi
<u>Steel</u>				
ASTM A1011 CS Type B	18,000	30,000(1)		29,000,000
ASTM A1011 SS GR36	20,000	36,000	53,000	29,000,000
ASTM A36	20,000	36,000	58,000	29,000,000
<u>Stainless Steel</u>				
ASTM A666 Type 304	20,000	30,000	75,000	28,000,000
ASTM A666 Type 304L	16,500	25,000	70,000	28,000,000
ASTM A666 Type 316	20,000	30,000	75,000	28,000,000
ASTM A666 Type 316L	16,500	25,000	70,000	28,000,000
<u>Aluminum*</u>				
ASTM B221 6061-T6	12,000	35,000	38,000	10,000,000
ASTM B221 6063-T6	12,000	25,000	30,000	10,000,000

- None of the designs for MBG grating are for welded aluminum construction. The allowable stresses listed may be below the values recommended by the Aluminum Association to assure acceptable serviceability and performance

METRIC

<u>Material</u>	Allowable Design Stress F MPa	Yield Strength F _y MPa	Tensile Strength F _u MPa	Modulus of Elasticity E MPa
<u>Steel</u>				
ASTM A1011M CS Type B	124.11	205(1)		200,000
ASTM A1011M SS GR250	137.90	250	365	200,000
ASTM A36M	137.90	250	400	200,000
<u>Stainless Steel</u>				
ASTM A666 Type 304	137.90	205	515	193,000
ASTM A666 Type 304L	113.77	170	485	193,000
ASTM A666 Type 316	137.90	205	515	193,000
ASTM A666 Type 316L	113.77	170	485	193,000
<u>Aluminum</u>				
ASTM B221M 6061-T6	82.74	240	260	69,000
ASTM B221M 6063-T6	82.74	170	205	69,000

(1) Based on many years of architectural metal experience.

FORMULAS

1. Number of bearing bars per foot of width for welded grating

$$K = 12/A_w$$

2. Section modulus of rectangular bearing bar
 $S_b = bd^2/6 \text{ in}^3$. Section modulus of grating per foot of width
 $S_g = Kbd^2/6 \text{ in}^3 = KS_b \text{ in}^3$
4. Section modulus required for given moment and allowable stress
 $S = M/F \text{ in}^3$
5. Moment of inertia of rectangular bearing bar
 $I_b = bd^3/12 \text{ in}^4 = S_b d/2 \text{ in}^4$
6. Moment of inertia of grating per foot of width
 $I_g = Kbd^3/12 \text{ in}^4 = KI_b \text{ in}^4$
7. Bending moment for given allowable stress and section modulus
 $M = SF \text{ lb-in}$

The following formulas are for simply supported beams with maximum moments and deflections occurring at mid-span.

8. Maximum bending moment under concentrated load
 $M = CL/4 \text{ lb-in per foot of grating width}$
9. Concentrated load to produce maximum bending moment
 $C = 4M/L \text{ lb per foot of grating width}$
10. Maximum bending moment under uniform load
 $M = UL^2/(8 \times 12) = UL^2/96 \text{ lb-in per foot of grating width}$
11. Uniform load to produce maximum bending moment
 $U = 96M/L^2 \text{ psf}$
12. Maximum bending moment due to partially distributed uniform load
 $M = P_u (2L - a)/8 \text{ lb-in}$
13. Maximum deflection under concentrated load
 $D_c = CL^3/48EI_g \text{ in.}$
14. Moment of inertia for given deflection under concentrated load
 $I_g = CL^3/48ED_c \text{ in}^4$
15. Maximum deflection under uniform load
 $D_u = 5UL^4/(384 \times 12EI_g) = 5UL^4/4608EI_g \text{ in.}$
16. Moment of inertia for given deflection under uniform load
 $I_g = 5UL^4/4608ED_u \text{ in}^4$
17. Maximum deflection under partially distributed uniform load
 $D_u = P_u((a/2)^3 + L^3 - a^2 L/2)/48EI_b \text{ in.}$

SAMPLE CALCULATIONS

Example 1

These calculations show the procedures used to prepare data for metal bar grating load tables.

The concentrated midspan and uniform load bearing capabilities of W-19-4 (1-1/2 x 3/16) welded A1011 CS Type B carbon steel grating and the corresponding midspan deflections will be calculated.

Allowable stress, $F = 18,000$ psi
Modulus of elasticity, $E = 29,000,000$ psi
Span, $L = 54$ in.
Bearing bar spacing, $A_w = 1.1875$ in.

Number of bearing bars per foot of width
 $K = 12/A_w = 12/1.1875 = 10.105$

Section modulus of grating per foot of width
 $S_g = Kbd^2/6 = 10.105 \times 0.1875 (1.5)^2/6 = 0.711$ in³

Moment of inertia of grating per foot of width
 $I_g = Kbd^3/12 = 10.105 \times 0.1875 (1.5)^3/12 = 0.533$ in⁴

Maximum bending moment for grating per foot of width
 $M_g = FS_g = 18,000 \times 0.711 = 12,800$ lb-in

Concentrated Load

Load, $C = 4M_g/L = 4 \times 12,800/54 = 948$ pfw
Defl, $D_c = CL^3/48EI_g = 948 \times (54)^3/(48 \times 29,000,000 \times 0.533) = 0.201$ in.

Uniform Load

Load, $U = 96M_g/L^2 = 96 \times 12,800/(54)^2 = 421$ psf
Defl, $D_u = 5UL^4/4608EI_g = 5 \times 421 \times (54)^4/(4608 \times 29,000,000 \times 0.533) = 0.251$ in.

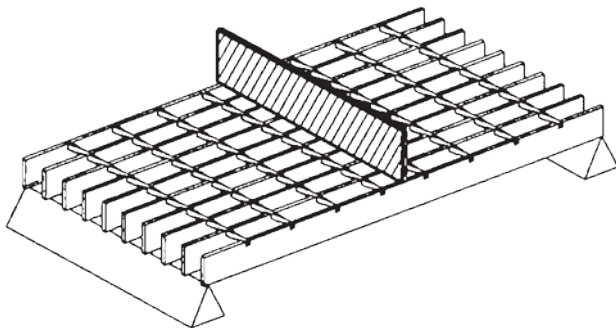

Concentrated Mid Span Load per foot of width

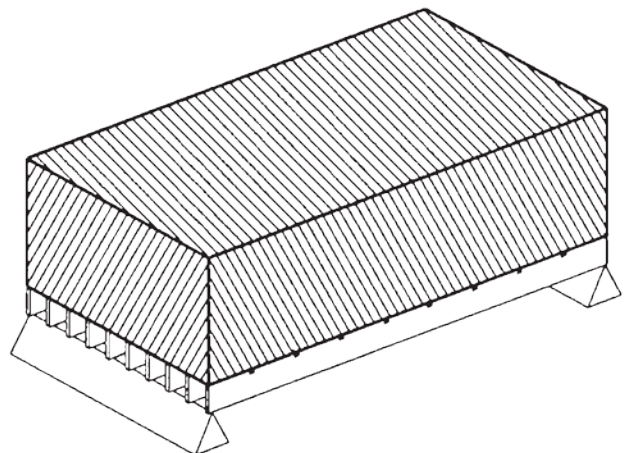

Uniform Load per square foot

GRATING SELECTION

Example 2 - Concentrated Load

Required: A welded ASTM A36 steel grating Type W-22-4 to support a concentrated load, C , of 4,000 pounds per foot of width at midspan on a clear span of 8'-0". Deflection, D , is not to exceed the 0.25" recommended for pedestrian comfort.

Allowable stress, $F = 20,000$ psi

Modulus of elasticity, $E = 29,000,000$ psi

Span, $L = 96$ in.

Bearing bar spacing, $A_w = 1.375$ in. $K = 12/A_w = 12 / 1.375 = 8.727$

For a span of 8'-0", the minimum size bearing bar to sustain a 4,000 pfw load is:

3 x 3/8

$$I_g = Kl_b = 8.727 \times 0.8438 = 7.364 \text{ in}^4 \quad S_g = KS_b = 4.909 \text{ in}^3$$

$$C = 4M_g/L = 4 \times F \times S_g/96 = 4 \times 20,000 \times 4.909/96 = 4,091 \text{ pfw}$$

$$D_c = CL^3/48EI_g = 4,000 \times (96)^3/(48 \times 29,000,000 \times 7.364) = 0.345 \text{ in.}$$

Since this exceeds the recommended limitation, a grating with a larger moment of inertia is needed to keep the deflection less than 0.25 in.

$$I_g = CL^3/48ED_c = 4,000 \times (96)^3/(48 \times 29,000,000 \times 0.25) = 10.17 \text{ in}^4$$

Using the next larger size:

3-1/2 x 3/8

$$I_g = 8.727 \times 1.3398 = 11.693 \text{ in}^4$$

$$S_g = 8.727 \times 0.7656 = 6.682 \text{ in}^3$$

$$C = 4 \times 20,000 \times 6.682/96 = 5,568 \text{ pfw}$$

$$D = 5,568 \times (96)^3/(48 \times 29,000,000 \times 11.693) = 0.303 \text{ in.}$$

Deflection is directly proportional to load:

$$D_c = 0.303 \times 4,000/5,568 = 0.217 \text{ in.} \leq 0.25 \text{ in. OK}$$

GRATING SELECTION

Example 3 - Uniform Load

Required: A 6063-T6 aluminum grating Type P-19-4 to support a uniform load, U , of 300 pounds per square foot on a clear span of 5'-0". Deflection, D , is not to exceed the 0.25" recommended for pedestrian comfort.

Allowable stress, $F = 12,000$ psi

Modulus of elasticity, $E = 10,000,000$ psi

Span, $L = 60$ in.

Bearing bar spacing, $A_w = 1.1875$ in. $K = 12/A_w = 12/1.1875 = 10.105$

For a span of 5'-0", the minimum size bearing bar to sustain a 300 psf load is:

1-3/4x3/16

$$I_g = Kl_b = 10.105 \times 0.0837 = 0.846 \text{ in}^4$$

$$S_g = KS_b = 10.105 \times 0.0957 = 0.967 \text{ in}^3$$

$$U = 96M_g/L^2 = 96 \times F \times S_g/(60)^2 = 96 \times 12,000 \times 0.967/(60)^2 = 309 \text{ psf}$$

$$D_u = 5UL^4/4608EI_g = 5 \times 309 \times (60)^4/(4608 \times 10,000,000 \times 0.846) = 0.514 \text{ in.}$$

Deflection is directly proportional to load:

$$D_u = 0.514 \times 300/309 = 0.499 \text{ in.}$$

Since this exceeds the recommended limitation, a grating with a larger moment of inertia is needed to keep the deflection less than 0.25 in.

$$I_g = 5UL^4/4608ED_u = 5 \times 300(60)^4/(4608 \times 10 \times 10^6 \times 0.25) = 1.6875 \text{ in}^4$$

Using a larger size:

$$2\text{-}1/4 \times 3/16 \quad I_g = 1.798 \text{ in}^4 \quad U = 512 \text{ psf} \\ D = 0.400 \text{ in.}$$

$$D_u = 0.400 \times 300/512 = 0.234 \text{ in.} \leq 0.25 \text{ in. OK}$$

Note: Uniform loads in these examples and in the standard load tables do not include the weight of the gratings. In designing for uniform live loads the weight of the grating, as well as any other dead load, must be added.

GRATING SELECTION

Example 4 -Partially Distributed Uniform Load

Required: A welded ASTM A1011 CS Type B steel grating Type W-19-4 to support a partially distributed uniform load, P_u , of 1,500 pounds over an area of 6" x 9" centered at midspan on a clear span of 3'-6". Deflection, D , is not to exceed the 0.25" recommended for pedestrian comfort.

Allowable stress, $F = 18,000$ psi
 Modulus of elasticity, $E = 29,000,000$ psi
 Span, $L = 42$ in.
 Bearing bar spacing, $A_w = 1.1875$ in.

Since the 6" x 9" load is rectangular, two conditions must be investigated to determine which condition places the greater stress on the grating:

Condition 'A' - 6" dimension parallel to bearing bars
 Condition 'B' - 9" dimension parallel to bearing bars

Condition 'A' $a = 6''$ $c = 9''$

Find maximum bending moment with load centered at midspan

$$M = P_u(2L-a)/8 = 1,500 \times (2 \times 42 - 6)/8 = 14,625 \text{ lb-in}$$

Find number of bars supporting load

$$N = c/A_w = 9/1.1875 = 7.58$$

Maximum bending moment per bearing bar

$$M_b = M/N = 14,625/7.58 = 1,929 \text{ lb-in}$$

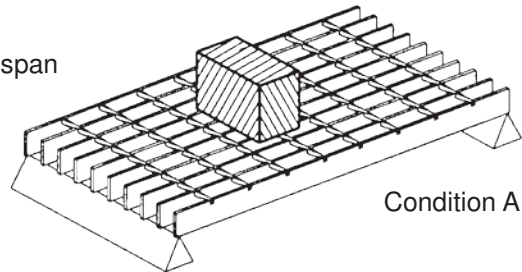

Condition A

Condition 'B' $a = 9''$ $c = 6''$

Find maximum bending moment with load centered at midspan

$$M = P_u(2L - a)/8 = 1,500 \times (2 \times 42 - 9)/8 = 14,063 \text{ lb-in}$$

Find number of bars supporting load

$$N = c/A_w = 6/1.1875 = 5.05$$

$$M_b = M/N = 14,063/5.05 = 2,785 \text{ lb-in}$$

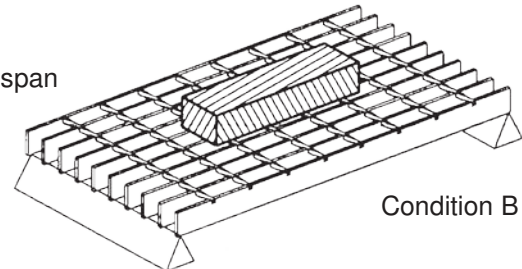

Condition B

Condition 'B' produces greater bending moment and will be used to establish grating size.

Required section modulus, $S_b = M_b/F = 2,785/18,000 = 0.155 \text{ in}^3$

From Table A on page 19, select:

$$2\text{-}1/4 \times 3/16 \text{ bar} \quad S_b = 0.1582 \text{ in}^3 \quad I_b = 0.1780 \text{ in}^4$$

Check deflection:

$$\begin{aligned} D_u &= P_u((a/2)^3 + L^3 - a^2 L/2)/48E I_b N \\ &= 1,500 \times ((9/2)^3 + 42^3 - 9^2 \times 42/2)/(48 \times 29 \times 10^6 \times 0.1780 \times 5.05) \\ &= 0.087 \text{ in.} < 0.25 \text{ in.} \end{aligned}$$

STAIR TREADS

Grating stair tread design calculations are based on the following assumptions:

1. The front or nosing area of the tread receives the greatest load and use under normal conditions. The back or rear area of the tread is seldom used.

1.1. The strength of the tread is determined by and limited to the front 5 inches of the tread.

1.2. The bearing area of the nosing is approximately 1-1/4" wide. The number of bearing bars considered to be carrying the load depends on their center to center spacing and is determined by the formula:

$$N = (5 - \text{nosing width}) / (\text{center to center distance of bars}) + 1$$

For 1-3/16 in. spacing,

$$N = (5 - 1.25) / (1.1875) + 1 = 4$$

For 15/16 in. spacing,

$$N = (5 - 1.25) / (0.9375) + 1 = 5$$

In calculating the strength of treads, the nosing plus "N" bearing bars is used.

2. For steel grating, all nosing is considered to have the strength of an angle 1-1/4" x 1-1/4" x 1/8".
(S = 0.049 in³; I = 0.044 in⁴)

For aluminum grating, all nosing is considered to have the strength of an angle 1-1/4" x 1-1/4" x 3/16".
(S = 0.071 in³; I = 0.061 in⁴)

These are the standard support angles used for cast abrasive nosings. Other shapes and configurations may be used by various manufacturers, but to conform to NAAMM Standards, the nosing must meet or exceed the physical characteristics of these angles.

3. The tread is to support a midspan concentrated design load of 300 pounds with a deflection not to exceed L/240. $L = \sqrt{EI/5P}$

4. Treads over 5'-6" are to support the design load of 300 pounds at the one-third points of the span since loads may be applied at two points on longer treads. Deflection should not exceed L/240.

$$L = \sqrt{EI/8.5P}$$

Example 5

SAMPLE CALCULATIONS FOR TREAD DESIGN

5A. Determine the maximum span length for a tread with 1-1/4" x 3/16" bearing bars on 1-3/16" centers. Use ASTM A1011 CS Type B steel.

Allowable design stress	F = 18,000 psi	
Nosing	S _n = 0.049 in ³	I _n = 0.044 in ⁴
1-1/4 x 3/16 bar	S _b = 0.0488 in ³	I _b = 0.0305 in ⁴

$$N = (5 - 1.25) / (1.1875) + 1 = 4$$

$$\text{Design } S = S_n + NS_b = 0.049 + 4 \times 0.0488 = 0.244 \text{ in}^3$$

$$\text{Design } I = I_n + NI_b = 0.044 + 4 \times 0.0305 = 0.166 \text{ in}^4$$

Resisting Moment, $M = SF = 0.244 \times 18,000 = 4,390 \text{ lb-in}$

Tread Span Length, $L = 4M/C = 4 \times 4,390 / 300 = 58.5 \text{ in.}$

$L = \sqrt{EI/5P} = \sqrt{29,000,000 \times 0.166 / (5 \times 300)} = 56.6 \text{ in. (controls)}$

5B. Determine the maximum span length for a tread with 1 x 3/16" bearing bars on 1-3/16" centers. Use ASTM A1011 CS Type B steel.

1 x 3/16 bar $S_b = 0.0313 \text{ in}^3$ $I_b = 0.0156 \text{ in}^4$
Nosing properties and allowable design stress from "5A."

Design $S = 0.049 + 4 \times 0.0313 = 0.1742 \text{ in}^3$

Design $I = 0.044 + 4 \times 0.0156 = 0.1064 \text{ in}^4$

Resisting Moment, $M = 0.1742 \times 18,000 = 3,140 \text{ lb-in}$

Tread Span Length, $L = 4M/C = 4 \times 3,140 / 300 = 41.8 \text{ in. (controls)}$

$L = \sqrt{EI/5P} = \sqrt{29,000,000 \times 0.1064 / (5 \times 300)} = 45.3 \text{ in.}$

5C. Determine the maximum span length for a tread with 1-1/4" x 3/16" bearing bars on 1-3/16" centers. Use 6063-T6 aluminum.

Allowable Design Stress, $F = 12,000 \text{ psi}$
Nosing $S_n = 0.071 \text{ in}^3$ $I_n = 0.061 \text{ in}^4$
1-1/4" x 3/16" $S_b = 0.0488 \text{ in}^3$ $I_b = 0.0305 \text{ in}^4$

Design $S = 0.071 + 4 \times 0.0488 = 0.266 \text{ in}^3$

Design $I = 0.061 + 4 \times 0.0305 = 0.183 \text{ in}^4$

Resisting Moment, $M = SF = 0.266 \times 12,000 = 3,190 \text{ lb-in}$

Tread Span Length, $L = 4M/C = 4 \times 3,190/300 = 42.5 \text{ in.}$

$L = \sqrt{EI/5P} = \sqrt{10,000,000 \times 0.183 / (5 \times 300)} = 34.9 \text{ in. (controls)}$

5D. Determine the maximum span length for a tread with 1" x 3/16" bearing bars on 1-3/16" centers. Use 6063-T6 aluminum.

1" x 3/16" bar $S_b = 0.0313 \text{ in}^3$ $I_b = 0.0156 \text{ in}^4$
Nosing properties and allowable design stress from "5C".

Design $S = 0.071 + 4 \times 0.0313 = 0.1962 \text{ in}^3$

Design $I = 0.061 + 4 \times 0.0156 = 0.1234 \text{ in}^4$

Resisting Moment, $M = SF = 0.1962 \times 12,000 = 2,350 \text{ lb-in}$

Tread Span Length, $L = 4M/C = 4 \times 2,350/300 = 31.3 \text{ in.}$

$L = \sqrt{EI/5P} = \sqrt{10,000,000 \times 0.1234 / (5 \times 300)} = 28.6 \text{ in. (controls)}$

5E. Determine the bearing bar size for a tread with bearing bars at 1-3/16" on center having a length of 6'-4". Use ASTM A1011 CS Type B steel. Assume a bearing bar thickness of 3/16 and find the bearing bar depth:

Load distribution for treads over 5'-6":

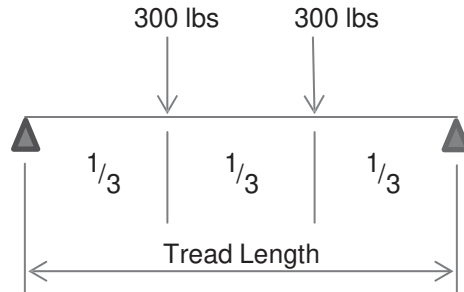

Design Formula:

$$L = \sqrt{EI/8.5P}$$

$$L = 76 \text{ inches}$$

$$E = 29,000,000 \text{ lb/in}^2$$

$$P = 300 \text{ lbs}$$

$$I = 8.5PL^2 / E = 8.5 \times 300 \times 76^2 / 29,000,000 = 0.5079 \text{ in}^4$$

$$\text{Design } I = I_n + N I_b$$

$$I_n = 0.044 \text{ in}^4$$

$$I = 0.5079 \text{ in}^4$$

$$N = 4$$

$$I_b = (I - I_n) / N = (0.5079 - 0.044) / 4 = 0.1160 \text{ in}^4$$

$$I_b = bd^3/12$$

$$I_b = \text{moment of inertia per bearing bar, in}^4$$

$$b = \text{thickness of bearing bar, in}$$

$$d = \text{depth of bearing bar, in}$$

$$d^3 = (12 \times I_b) / b = (12 \times (0.116)) / (.1875) = 7.424 \text{ in}^3$$

$$d = 1.9508 \text{ in}$$

Therefore, for a Type 19-4 tread with a length of 6'-4" the recommended bearing bar size would be 2 x 3/16".

Check for stress:

$$F = 18,000 \text{ psi}$$

$$S = S_n + N S_b = 0.049 + 4(0.125) = 0.549 \text{ in}^3$$

$$\text{Resisting moment } M = SF = 0.549 \times 18,000 = 9,882 \text{ in lbs}$$

$$\text{Maximum moment applied} = 300 (76/3) = 7,600 \text{ in lbs}$$

Deflection controls

Vehicular Loads

Welded and Pressure Locked Construction

The following load criteria and design calculations (Examples 6 and 7) were used to prepare data for the Vehicular Load Tables found in NAAMM publication MBG-532, "Heavy Duty Metal Bar Grating Manual". These examples apply to welded and pressure locked gratings only (for riveted gratings see the design calculations related to Example 8).

Load distribution criteria conforms with the AASHTO Standard Specification for Highway Bridges, 16th Edition, paragraph 3.27.3.1. This specification for open floors states that H-20 / HS-20 loads shall be distributed over an area 20" x 20" plus one bearing bar on each side of the wheel load. The wheel load for H-20 / HS-20 loads is 20,800 lbs. which includes a 30% impact factor per paragraph 3.8.2.1.

For maximum service life it is recommended that deflection for gratings subject to vehicular loads be restricted to the lesser of .125 inches or L/400. Additionally, to reduce the effects of impact and fatigue, it is recommended that gratings subject to heavy, high speed or multi-directional traffic be specified with load carrying banding.

LOAD CRITERIA – Vehicular Loads (Applicable to all gratings)

	AASHTO H-25	AASHTO H-20	AASHTO H-15	Passenger Vehicles	5 Ton Forklifts	3 Ton Forklifts	1 Ton Forklifts
Truck/Vehicle Weight (pounds)				6,322	14,400	9,800	4,200
Load Capacity (pounds)				3,578	10,000	6,000	2,000
Axle Load (pounds)	40,000	32,000	24,000				
Impact Factor	30%	30%	30%	30%	30%	30%	30%
Total Load (pounds)	52,000	41,600	31,200	12,870	31,720	20,540	8,060
% of load on drive axle				60%	85%	85%	85%
Pw = Wheel Load (pounds)	26,000	20,800	15,600	3,861	13,481	8,730	3,426
a = Length of Distribution parallel to bearing bars (inches)	25	20	15	9	11	7	4
c = Width of Distribution perpendicular to bearing bars (inches)	25 *	20 *	15 *	9 *	11 *	7 *	4 *
	* plus 2 x the center/center spacing of bearing bars						

Design Calculations:

S_b = section modulus per bar, in³

F = allowable stress, psi

a = length of distribution parallel to bearing bar, in

c = width of distribution perpendicular to bearing bar, in

P_b = load per bar, lb

E = modulus of elasticity, psi

I_b = I of bearing bar, in⁴

L = clear span, in

$$\text{Maximum Span} = 4((S_b / (P_b/F)) + (a / 8))$$

$$\text{Deflection - Max Span} = [P_b / (96)(E)(I_b)] [2(L)^3 - a^2 \times L + a^3/4]$$

Example 6 - Vehicular Load Calculations

Required: Determine maximum span for A-36 carbon steel grating, type W-22-4 3-1/2" x 3/8" for AASHTO H-20 loads. Deflection to be the lesser of .125 inches or L / 400.

Proposed Grating:	W-22-4 3-1/2" x 3/8"
Bearing bar spacing	1.375"
Bearing bar depth	3-1/2"
Bearing bar thickness	0.375"

Area of Distribution:

a = Parallel to bearing bars = 20"

c = Perpendicular to bearing bars = 22.75"

P_w = Wheel Load = 20,800 lb.

Material: A-36 Carbon Steel

F = 20,000 psi

E = 29,000,000 psi

N = Number of bars supporting load = c / 1.375 = 16.545

P_b = load per bar = (P_w / N) = 1,257 lb.

P_b / F = .0629, in²

$I_b = bd^3 / 12 = 1.3398$ in⁴

$$\text{Maximum Span} = 4((S_b / (P_b/F)) + (a / 8)) = 58"$$

$$\text{Deflection - Maximum Span} = [P_b / (96)(E)(I_b)] [2(L)^3 - a^2 \times L + a^3/4] = .124"$$

Partially Distributed Vehicular Loads

The following design calculations were used to prepare data for vehicular loads when the tire contact length exceeds the clear span of the grating.

Example 7 – Partially Distributed Vehicular Load

Required: Determine a type W-22-4, A-36 carbon steel grating, capable of supporting H-20 loads over a 15 inch clear span, maximum deflection not exceeding the lesser of .125 inches or L/400.

Load Condition: AASHTO H-20

Area of Distribution:

a = Length of distribution parallel with bearing bars = 20"
c = Width of distribution perpendicular to bearing bars = 22.75"
 P_w = Wheel load (pounds) = 20,800 lb.

Proposed Grating: W-22-4 1-1/2" x 1/4"

Bearing bar spacing 1.375"
Bearing bar depth 1.50"
Bearing bar thickness .25"

Material: A-36 Carbon Steel

F = 20,000 psi

E = 29,000,000 psi

L = clear span in inches = 15"

M = maximum bending moment = $(P_w/a)(L^2/8) = 29,250$ in. lb.

S_g = required section modulus of grating = $M / F = 1.4625$ in³

A_w = center to center spacing of bearing bars = 1.375"

N = number of bars supporting load = $c / A_w = 16.5455$

S_b = required section modulus per bar = $S_g / N = .089$ in³/bar

Section Modulus Required per Bar = .089 in³

Section Modulus of Proposed Bar = 0.094 in³

Deflection Calculation:

I_b = Moment of inertia of proposed bar = $b \times d^3 / 12 = 0.070$ in⁴/bar

I_g = Moment of inertia - grating = $I_b \times N = 1.163$ in⁴

Deflection = $((5 \times (P_w/a) L^4)) / (384 E I_g)$

Deflection equals = 0.020"

(Deflection \leq .125" and L/400)

Riveted Heavy Duty Gratings

The following design calculations were used to prepare data for the Vehicular Load Tables found in NAAMM publication MBG-532, "Heavy Duty Metal Bar Grating Manual". These design calculations and Example 8 apply specifically to type R-37-5 Riveted Grating.

Example 8 – Riveted Heavy Duty Vehicular Loads

Determine the maximum clear span "L" with simple supports for type R-37-5 size 5" x 1/4" A-36 Steel heavy duty riveted grating under AASHTO / HS-20 loading with maximum impact factor of 30%.

Design Formulas and Descriptions:	Values
S_{H20b} = Section modulus at bottom of grating under HS-20 loading.	= 11.56 (see calculations below)
I_{H20} = Moment of inertia of grating under HS-20 loading	= 32.305 (see calculations below)
F = Max allowable fiber stress for ASTM A36 steel	= 20,000 psi
a = Length of load distribution parallel to bearing bars	= 20"
c = Width of load distribution perpendicular to bearing bars.*	= 20" + 2 bearing bars
A_c = Distance center to center of main bearing bars = $A_r + b$	= 2.5625"
N_{bH20} = Number of main bearing bars under load H-20	= 9.8 (see calculation below)
N_{cH20} = Number of connecting bearing bars under load	= 8.8 (see calculation below)
P_{UH20} = Partially distributed uniform load = Wheel load.	20,800 lbs
E = Modulus of elasticity (psi)	29,000,000 psi
M = Max moment applied to grating section	231,200 in lbs (see calculation below)
L = Maximum clear span (in inches)	54.5 inches (see calculation below)
Max moment = $M = S_{H20b} \times F$	Reference formula number 4
Maximum span $L = ((8M + (a \times P_{UH20})) / (2 P_{UH20}))$	Reference formula number 12
Deflection at max span = $P_{UH20} ((a/2)^3 + L^3 - a^2 L/2) / (48 E I_{H20})$	Reference formula number 17
* $c = a + 2 A_c$	Reference AASHTO Specification for Bridges 16th edition paragraph 3.27.3.1
$N_{bH20} = (a / A_c) + 2$	
$N_{cH20} = (a / A_c) + 1$	

Using the formulas above:

$$N_{bH20} = (20 / 2.5625) + 2 = 9.8 \text{ main bearing bars with each having thickness of } 0.25"$$

The depth of the main bearing bars is $d_{main} = 5"$

$$N_{cH20} = (20 / 2.5625) + 1 = 8.8 \text{ connecting bars with each having thickness of } 0.1875"$$

The depth of the connecting bars is $d_{connecting} = 1.5"$

The resulting section of riveted grating under load is modeled as a T section with dimensions shown below.

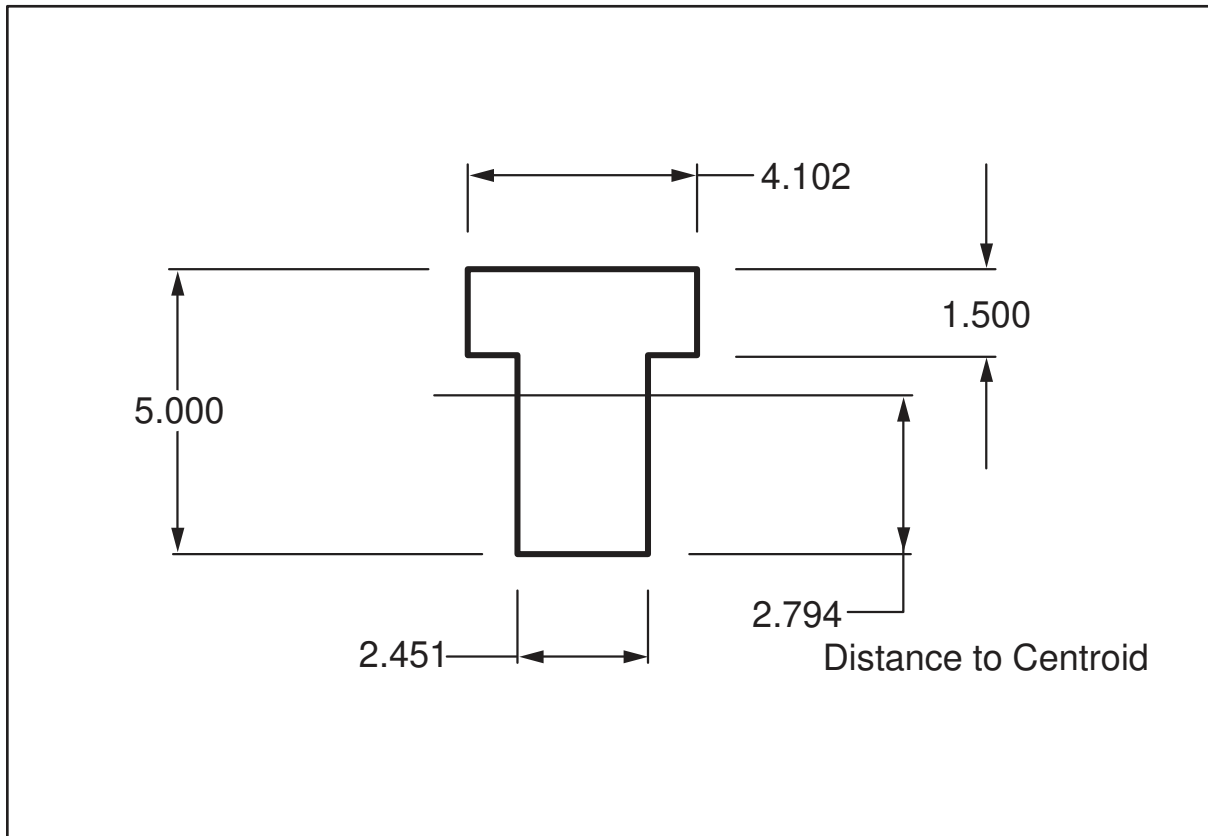

In the T section the centroid distance and second moment of inertia " I_{H20} " can be calculated using the parallel axis theorem.

$I_{H20} = 32.305 \text{ in}^4$ and the centroid distance to bottom is as shown 2.794"

$S_{H20b} = I_{H20} / \text{centroid distance to bottom} = 32.305 / 2.794 = 11.56 \text{ in}^3$

The maximum moment that can be applied to the section is

$M = S_{H20b} \times F = 11.56 \times 20,000 = 231,200 \text{ in lbs}$

Now using formula 12, Maximum Span is calculated as follows

$L = ((8 \times M) + (a \times P_{UH20})) / (2 P_{UH20}) = ((8 \times 231,200) + (20 \times 20,800)) / (2 \times 20,800) = 54.5 \text{ inches.}$

Deflection Calculation:

$$D_u = P_u [(a/2)^3 + L^3 - a^2 L/2] / (48 E I_{H20})$$

$$D_u = 20,800 [(20/2)^3 + (54.5)^3 - (20)^2 \times 54.5 / 2] / (48 \times 29,000,000 \times 32.305)$$

$$D_u = 0.070 \text{ in } (\leq .125" \text{ and } L/400)$$

METAL BAR GRATING DESIGN MANUAL

METRIC PRACTICE

The system of metric measurement used in this manual is from IEEE/ASTM SI 10-2002, "Standard for Use of the International System of Units (SI): The Modern Metric System."

SI prefixes:

$$k \text{ (kilo)} = 10^3$$

$$M \text{ (mega)} = 10^6$$

$$G \text{ (giga)} = 10^9$$

Corresponding units:

Length - meter, m millimeter, mm

Force - newton, N

Stress - pascal, Pa (newton/square meter)

Bending Moment - newton meter, N-m

Conversion factors:

$$1 \text{ in.} = 0.0254 \text{ m} = 25.4 \text{ mm}$$

$$1 \text{ in}^2 = 645.16 \text{ mm}^2$$

$$1 \text{ in}^3 = 16,387 \text{ mm}^3$$

$$1 \text{ in}^4 = 416,231 \text{ mm}^4$$

$$1 \text{ ft} = 0.3048 \text{ m} = 304.8 \text{ mm}$$

$$1 \text{ ft}^2 = 0.092903 \text{ m}^2 = 92,903 \text{ mm}^2$$

$$1 \text{ lb (force) (lb)} = 4.44822 \text{ N}$$

$$1 \text{ kip} = 4.44822 \text{ kN}$$

$$1 \text{ psi} = 4.44822\text{N}/645.16\text{mm}^2 = 0.006894757 \text{ N/mm}^2 = 6,894.757 \text{ N/m}^2 \\ = 6,894.757 \text{ Pa} = 6.894757 \text{ kPa} = 0.006894757 \text{ MPa}$$

$$1 \text{ psf} = 47.88026 \text{ Pa} = 0.04788026 \text{ kPa}$$

$$1 \text{ pfw} = 4.44822\text{N}/0.3048\text{m} = 14.5939 \text{ N/m of width}$$

Sample Calculations - Stainless Steel Bar Grating

Load bearing capabilities and corresponding midspan deflections of a W-19 (1 x 1/8) welded stainless steel grating are calculated.

Using ASTM A666 Type 304

Allowable stress, $F = 137.90 \text{ MPa}$

Modulus of elasticity, $E = 193,000 \text{ MPa}$

$$A_w = 1.1875 \text{ in.} = 30.16 \text{ mm}$$

$$K = 12/A_w = 12/1.1875 = 12 \times 25.4/30.16 = 10.105$$

$$S_g = Kbd^2/6 = 10.105 \times (0.125 \times 25.4) \times (1 \times 25.4)^2/6 = 3,450 \text{ mm}^3$$

$$I_g = Kbd^3/12 = 10.105 \times (0.125 \times 25.4) \times (1 \times 25.4)^3/12 = 43,800 \text{ mm}^4$$

If section modulus and moment of inertia are known in inch units, conversion is even simpler, and the result will be well within engineering accuracy.

If $S_g = 0.21 \text{ in}^3$ and $I_g = 0.1053 \text{ in}^4$, then

$$S_g = 0.21 \times 16,387 = 3,440 \text{ mm}^3$$

$$I_g = 0.1053 \times 416,231 = 43,800 \text{ mm}^4$$

To calculate loads and deflections for a 0.762 m (2'-6") span, the following procedures may be used:

Maximum bending moment for grating per 0.3048 m (1 ft) width

$$\begin{aligned} M_g &= F \times S_g = 137.90 \text{ MPa (N/mm}^2) \times 3,450 \text{ mm}^3 \\ &= 475,728 \text{ N mm} = 475.7 \text{ N m} \\ &\text{per 0.3048 m of width} \end{aligned}$$

Concentrated Load at Midspan

$$\begin{aligned} \text{Load, } C &= 4M_g/L = 4 \times 475.7/0.762 \\ &= 2,497 \text{ N per foot of width} \\ &= 2,497/(10^3 \times 0.3048) \\ &= 8.19 \text{ kN per meter of width} \end{aligned}$$

$$\begin{aligned} \text{Defl, } D_c &= CL^3/48EI \\ &= 2,497 \times 0.762^3 \times 10^9/(48 \times 193,000 \times 43,800) \\ &= 2.72 \text{ mm} \end{aligned}$$

Uniform Load

$$\begin{aligned} \text{Load, } U &= 8M_g/L^2 = 8 \times 475.6/0.762^2 \\ &= 6,553 \text{ N/m per foot of width} \\ &= 6,553/(10^3 \times 0.3048) \\ &= 21.50 \text{ kN/m}^2 \end{aligned}$$

$$\begin{aligned} \text{Defl, } D_u &= 5UL^4/384EI \\ &= 5 \times 6,553 \times 0.762^4 \times 10^9/(384 \times 193,000 \times 43,800) \\ &= 3.40 \text{ mm} \end{aligned}$$

TABLE A
SECTION MODULI AND MOMENTS OF INERTIA FOR RECTANGULAR BEARING BARS

S = Section Modulus, in³ (mm³)
I = Moment of Inertia, in⁴ (mm⁴)

Depth of Bar in. (mm)			Thickness of Bar in. (mm)							
			1/8 (3.2)	3/16 (4.8)	1/4 (6.4)	3/8 (9.5)				
3/4	(19.0)	S	0.0117 (192)	0.0176 (288)	0.0234 (383)	0.0352 (577)				
		I	0.0044 (1,830)	0.0066 (2,750)	0.0088 (3,660)	0.0132 (5,490)				
1	(25.4)	S	0.0208 (341)	0.0313 (513)	0.0417 (683)	0.0625 (1,024)				
		I	0.0104 (4,330)	0.0156 (6,490)	0.0208 (8,660)	0.0313 (13,000)				
1-1/4	(31.8)	S	0.0326 (534)	0.0488 (800)	0.0651 (1,067)	0.0977 (1,600)				
		I	0.0203 (8,450)	0.0305 (12,700)	0.0407 (16,940)	0.0610 (25,400)				
1-1/2	(38.1)	S	0.0469 (769)	0.0703 (1,152)	0.0938 (1,537)	0.1406 (2,300)				
		I	0.0352 (14,650)	0.0527 (21,900)	0.0703 (29,300)	0.1055 (43,900)				
1-3/4	(44.4)	S	0.0638 (1,045)	0.0957 (1,568)	0.1276 (2,090)	0.1914 (3,140)				
		I	0.0558 (23,200)	0.0837 (34,800)	0.1117 (46,500)	0.1675 (69,700)				
2	(50.8)	S	0.0833 (1,365)	0.1250 (2,050)	0.1667 (2,730)	0.2500 (4,100)				
		I	0.0833 (34,700)	0.1250 (52,000)	0.1667 (69,400)	0.2500 (104,000)				
2-1/4	(57.2)	S	0.1055 (1,728)	0.1582 (2,590)	0.2109 (3,460)	0.3164 (5,180)				
		I	0.1187 (49,400)	0.1780 (74,100)	0.2373 (98,800)	0.3560 (148,200)				
2-1/2	(63.5)	S	0.1302 (2,130)	0.1953 (3,200)	0.2604 (4,270)	0.3906 (6,400)				
		I	0.1628 (67,800)	0.2441 (101,600)	0.3255 (135,500)	0.4883 (203,000)				
3	(76.2)	S	0.1875 (3,070)	0.2813 (4,610)	0.3750 (6,140)	0.5625 (9,220)				
		I	0.2813 (117,000)	0.4219 (175,600)	0.5625 (234,000)	0.8438 (351,000)				
3-1/2	(88.9)	S	0.2552 (4,180)	0.3828 (6,270)	0.5104 (8,360)	0.7656 (12,550)				
		I	0.4466 (186,000)	0.6699 (279,000)	0.8932 (372,000)	1.3398 (558,000)				
4	(101.6)	S	0.3333 (5,460)	0.5000 (8,190)	0.6667 (10,920)	1.0000 (16,390)				
		I	0.6666 (277,000)	1.0000 (416,000)	1.3333 (555,000)	2.0000 (832,000)				
4-1/2	(114.3)	S	0.4219 (6,910)	0.6328 (10,370)	0.8438 (13,830)	1.2656 (20,700)				
		I	0.9492 (395,000)	1.4238 (593,000)	1.8984 (790,000)	2.8477 (1,185,000)				
5	(127.0)	S	0.5208 (8,534)	0.7813 (12,803)	1.0417 (17,070)	1.5625 (25,605)				
		I	1.3021 (542,000)	1.9531 (813,000)	2.6042 (1,084,000)	3.9063 (1,626,000)				

Note: The bearing bar sizes in this table are those which are covered in the NAAMM Metal Bar Grating Standards.

